

Geothermal Systems

The Good, The Bad, and The Ugly

Presentation by

John Bender, P.E.

MWSK Geothermal Inc.

Geothermal Systems

- Growing market for MEP firms
- Equipment vendors
- Used on my LEED projects
 - Energy Savings
 - Sustainability
 - Reduces Carbon Footprint
 - Wind
 - Nuclear
 - Hydroelectric
 - Solar

Geothermal Systems

- High Risk for MEP firms
- Problematic for Equipment vendors new to the market
- Used on my LEED projects
 - Energy Savings are over estimated in many cases due to improper system design by MEP firms
 - Are not sustainable when improperly designed

Geothermal Systems

QUESTION

How can one MEP firm have a
“Good Job”...

While others have “BAD Jobs”
and/or “UGLY Jobs”?

Geothermal Systems

What Defines

A “Good Job”?

A “Bad Job”?

An “UGLY Job”?

Geothermal Systems

Good Jobs

- Work properly in all seasons
- Meets or exceeds Energy Model presented to client (end user)
- Does not cause adverse effects to the Earth
- Can be used by MEP firms as sales tools to get more work of the same type

Geothermal Systems

Bad Jobs

- Work – but not properly
- Use substantially more energy than the energy model
- Cause adverse effects on the Earth
- Can't be used by MEP firms as sales tools to get more work of the same type

Geothermal Systems

UGLY Jobs

- Don't Work
- The original energy model is not even looked at because the system doesn't function
- Cause adverse effects on the Earth
- MEP is sued by client
- MEP might never do another GEO job

Geothermal Systems

Standard Job Scenarios

- 3 Different Hypothetical Engineers
 - Engineer “A” – UGLY Jobs
 - Engineer “B” – BAD Jobs
 - Engineer “C” – GOOD Jobs
- 2 Different Systems
 - High End Manhattan Residential
 - Public School on Long Island

Geothermal Systems

“JOB 1” Manhattan Residential

1. Wealthy Client – \$10 to \$30 million home
2. No true interest in being GREEN – doesn't want to see a cooling tower
3. Special Architecture..

Geothermal Systems

Job “1” Manhattan Residential

IMPORTANT DESIGN CRITERIA

1. System has to work
2. Owner wants max comfort
3. System must be “SILENT”
4. Doesn't have to be GREEN but owner could like the idea
5. Architect spending large amounts on interiors

Geothermal Systems

“JOB 1” Manhattan Residential
Engineer “A” – UGLY JOB

1. Standing Water Column – single hole
2. No heat exchanger
3. 2 pipe system with storage tank
4. Fan coils with PSC blowers

Engineer "A" - High End Manhattan Residential Job

UGLY JOB

Standing Water Column
No Heat Exchanger
Water to Water Heat Pumps
2 Pipe System with Fan Coils

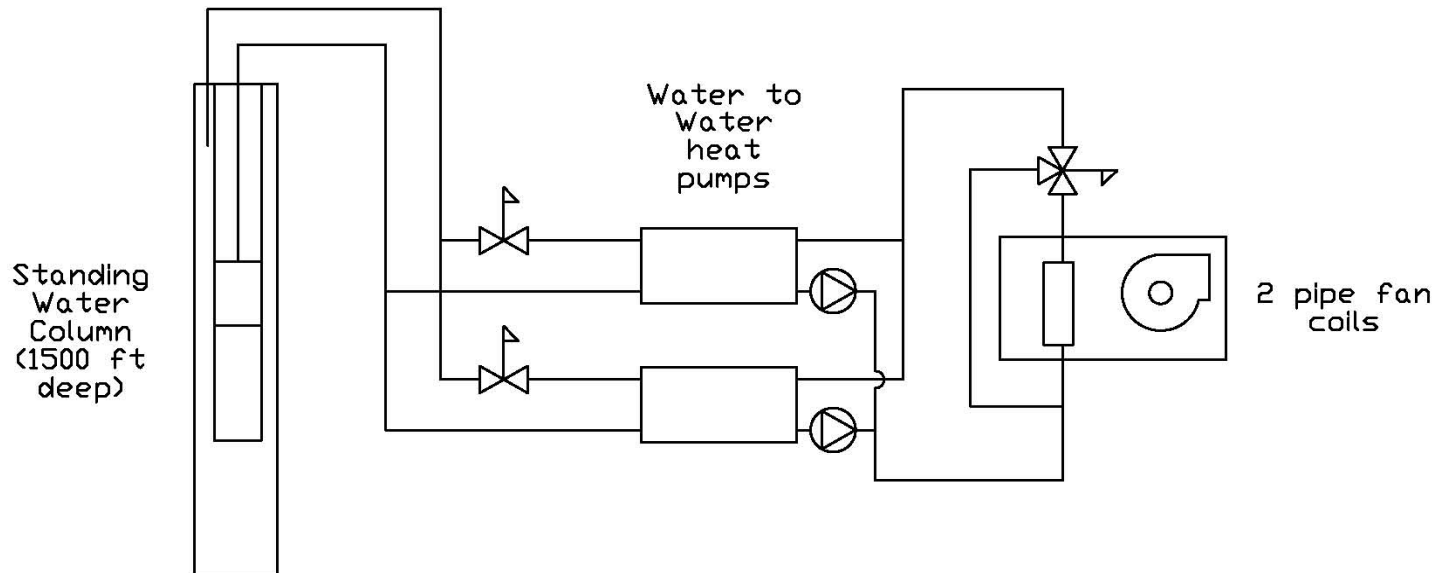

Geothermal Systems

“JOB 1” Manhattan Residential
Engineer “A” – UGLY JOB

Standing Water Column – single hole with
no heat exchanger

Hole has brackish water (salt) and corrodes
heat pumps and piping

Geothermal Systems

“JOB 1” Manhattan Residential
Engineer “A” – UGLY JOB

2 Pipe System with Storage Tank requires
several hours for change over

Very Loud - PSC blower in fan coil slams on
and off when thermostat calls

Geothermal Systems

“JOB 1” Manhattan Residential Engineer “B” – BAD JOB

1. Standing Water Column – single hole
2. No heat exchanger
3. 4 pipe system with storage tank
4. Fan coils with PSC blowers
5. Cupronickel heat exchangers in HP's

Engineer "B" - High End Manhattan Residential Job

BAD JOB

Standing Water Column
No Heat Exchanger
Water to Water Heat Pumps with CN Coax
4 Pipe System with Fan Coils

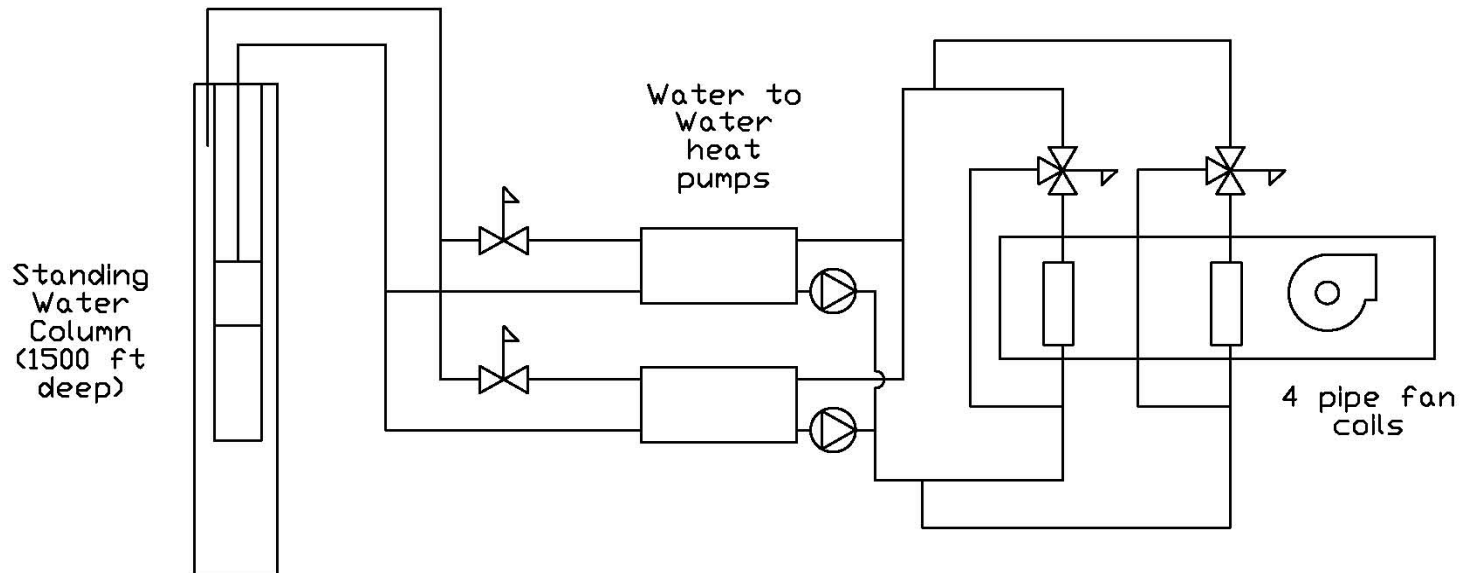

Geothermal Systems

“JOB 1” Manhattan Residential
Engineer “B” – BAD JOB

Standing Water Column – single hole with no
heat exchanger

Hole has brackish water (salt) and corrodes
piping

Heat Pumps are Protected

Geothermal Systems

“JOB 1” Manhattan Residential
Engineer “B” – BAD JOB

4 Pipe System gives better control

Very Loud - PSC blower in fan coil slams on
and off when thermostat calls

Geothermal Systems

“JOB 1” Manhattan Residential
Engineer “C” – GOOD JOB

1. Standing Water Column – single hole
2. Titanium Heat Exchanger
3. Water to air and water to water HP's
4. ECM Blowers

Engineer "C" - High End Manhattan Residential Job

GOOD JOB

Standing Water Column
Titanium Heat Exchanger
Water to Water Heat Pumps for Radiant Floor
Water to Air Heat Pumps with ECM Blowers

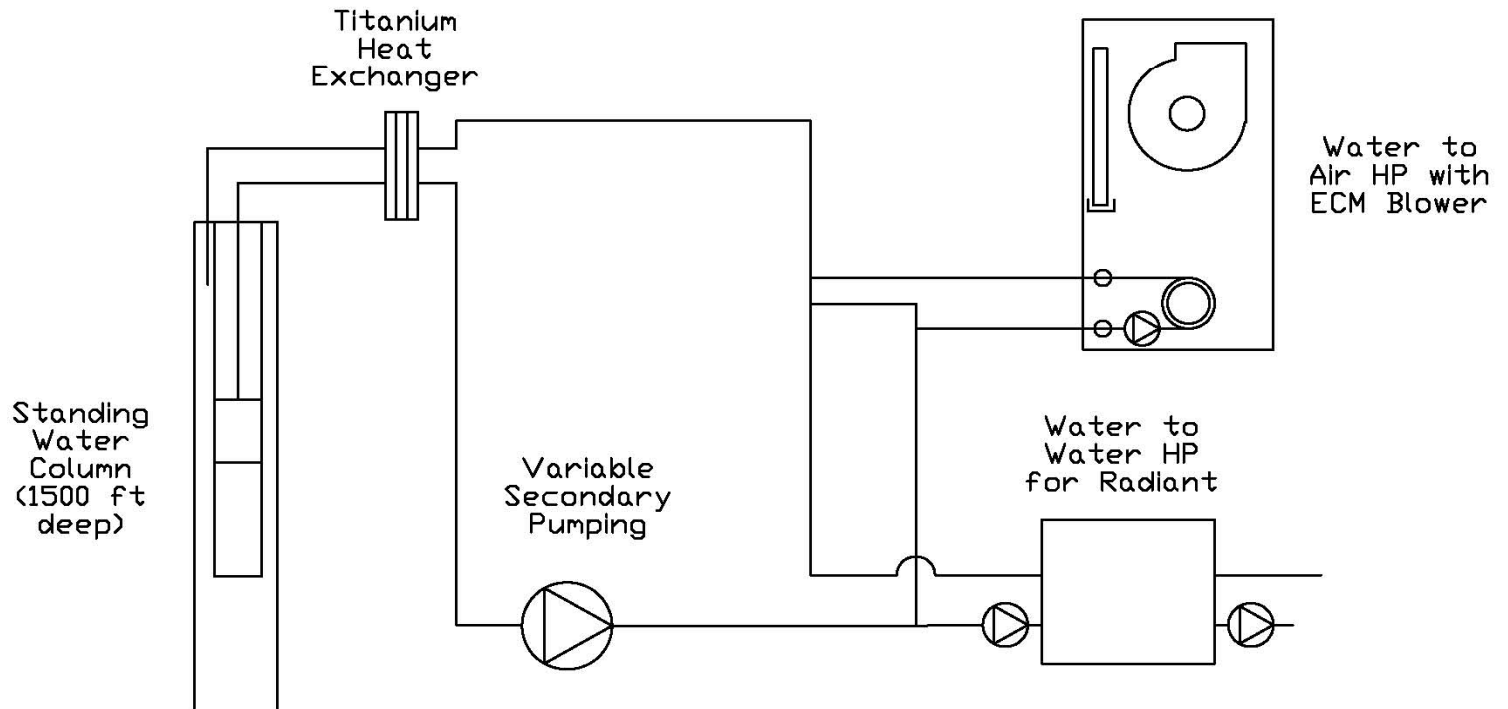

Geothermal Systems

“JOB 1” Manhattan Residential
Engineer “C” – GOOD JOB

Standing Water Column – single hole with
Titanium Heat Exchanger

Hole has brackish water (salt) and corrodes
very little

City Water Connection in building loop if
pump in water column goes down

Geothermal Systems

“JOB 1” Manhattan Residential
Engineer “C” – GOOD JOB

Heating or Cooling at any time

Very Quiet - ECM blower slowly ramps up

Heat pumps located in insulated closet or
insulated ceiling spaces to cut down on
compressor enable/disable “HUM”

Geothermal Systems

Job “2” LEED School – Long Island IMPORTANT DESIGN CRITERIA

1. System has to work
2. Owner wants to be GREEN and SUSTAINABLE
3. Job will have separate LEED commissioning agent and rebates from LIPA
4. MEP sells extra cost of field based on energy model

Geothermal Systems

“JOB 2” LEED School Long Island
Engineer “A” – UGLY JOB

1. Closed Loop Geothermal
2. Short Looped
3. Low efficiency heat pumps
4. No air side heat recovery

Engineer "A" - School Long Island - Closed Loop Geo

UGLY JOB

Hires Loop Consultant for Field
Doesn't review loop calculations
Low Efficiency Water to Air Heat Pumps
No Air Side Heat Recovery
Variable Primary Pumping with DP control

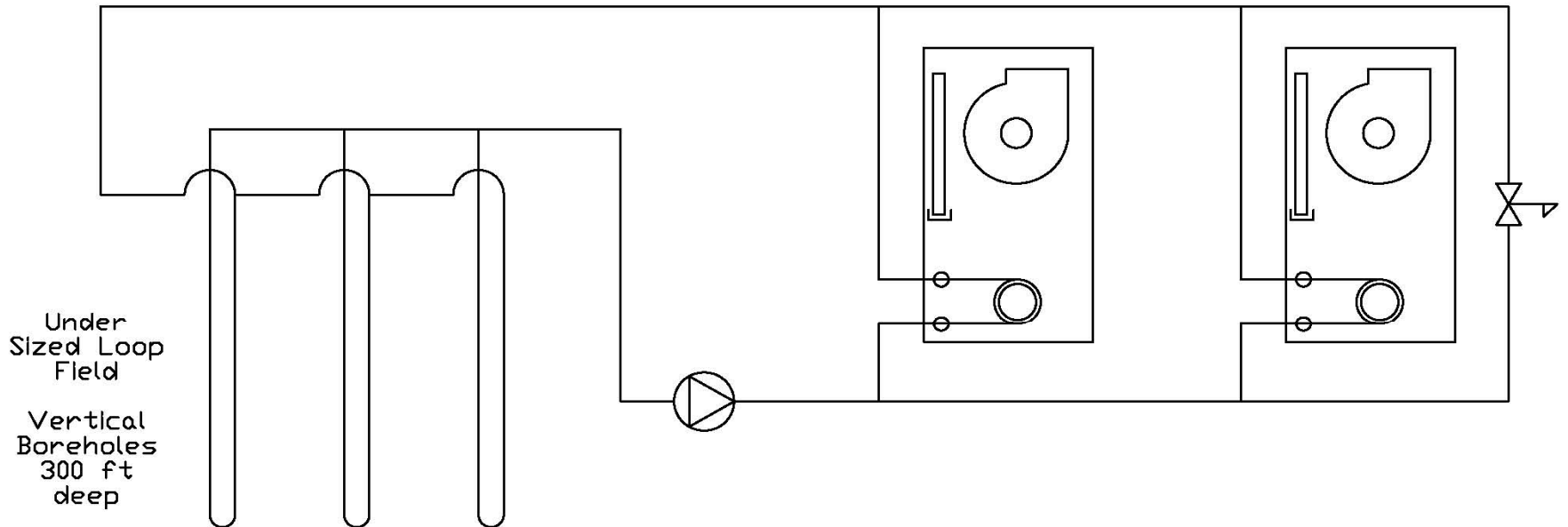

Geothermal Systems

“JOB 2” LEED School Long Island
Engineer “A” – UGLY JOB

Loop Field is too small

- Summer Operation hits 110F supply from field – high pressure trips
- Winter Operation hits 32F supply from field – low pressure/freeze trips

Geothermal Systems

“JOB 2” LEED School Long Island
Engineer “A” – UGLY JOB

Engineer’s Insurance Company
pays for Cooling Tower to be
installed

Geothermal Systems

“JOB 2” LEED School Long Island
Engineer “B” – BAD JOB

1. Closed Loop Geothermal
2. Cooling Dominant Building
3. Medium efficiency heat pumps
4. Air side heat recovery

Engineer "B" - School Long Island - Closed Loop Geo

BAD JOB

Hires Loop Consultant for Field
Puts in enough pipe for Cooling
Extremely Cooling Dominant Building (unbalanced field)
Medium Efficiency Water to Air Heat Pumps
Air Side Heat Recovery
Variable Primary Pumping with DP control

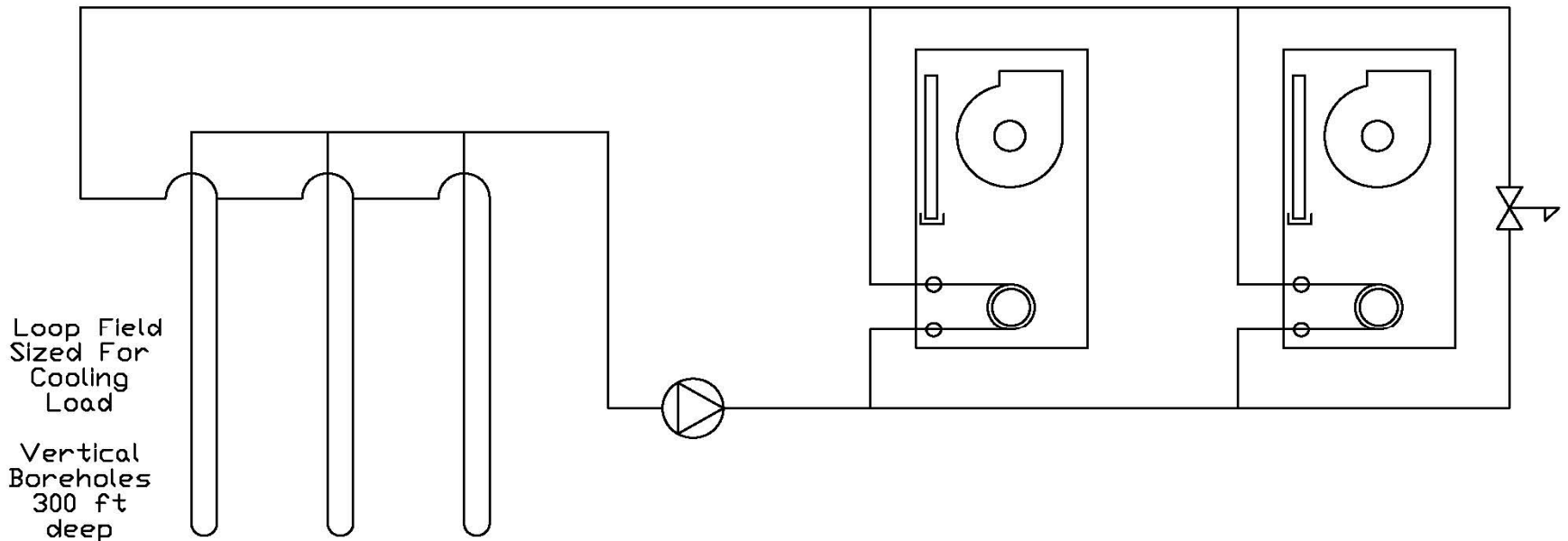

Geothermal Systems

“JOB 2” School Long Island
Engineer “B” – BAD JOB

Spends \$4000 per ton on a field AND...

Field heats up 15 degrees in 5
years due to high cooling
load / low heating load

Geothermal Systems

“JOB 2” School Long Island
Engineer “A” – UGLY JOB

Payback used to sell the concept to the
district is way off.

Geothermal Systems

“JOB 2” LEED School Long Island
Engineer “C” – GOOD JOB

1. Closed Loop Geothermal HYBRID
2. Sizes field for 80% of heating load
3. Has cooling tower and boiler in system
4. Saves money by using a 1 pipe system
5. Spends money on
 1. Ultra High Efficiency heat pumps
 2. Top of the line ventilation system

Engineer "C" - School Long Island - Closed Loop Geo

GOOD JOB

Hires Loop Consultant for Field
Puts in Hybrid System with Cooling Tower and Boiler
High Efficiency Water to Air Heat Pumps
Air Side Heat Recovery with low dew point discharge
One Pipe System with Primary/Secondary pumping

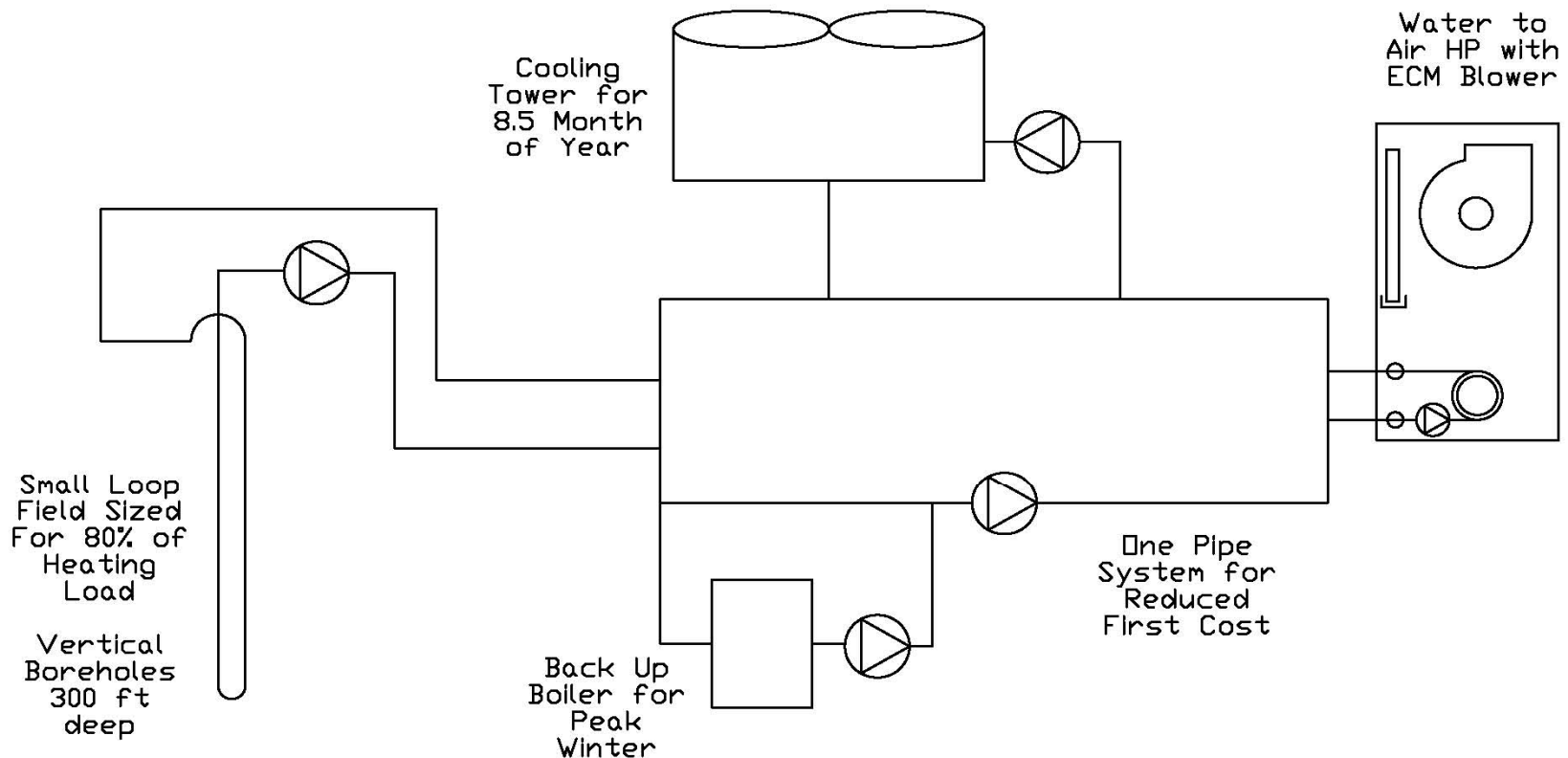

Geothermal Systems

“JOB 2” School Long Island
Engineer “C” – GOOD JOB

Small field with tower and boiler is lowest
first cost

Tower is drained 4 months out of the year

Geothermal Systems

“JOB 2” School Long Island
Engineer “C” – GOOD JOB

Designs system with a one
pipe distribution system to
cut the \$/ft²

Geothermal Systems

“JOB 2” School Long Island
Engineer “C” – GOOD JOB

Engineer uses the best heat pump
and ventilation system to cut
KW consumption

Reduces KW/ft²

Geothermal Systems

Key to Good Jobs

- Work properly in all seasons
- Meet or exceed Energy Model presented to client (end user)
- Does not cause adverse effects to the Earth
- Can be used by MEP firms as sales tools to get more work of the same type